

eeZee Mouse Pro

Operating Instructions

1.0 System Requirements

Hardware: Host computer or SGD with powered USB connector

Software:

- Microsoft Windows™: 7, Vista, XP, ME, 2000, 98 (with CD)
- OS X™ 8.0 or above
- Unix™ / Linux / any utilizing standardized HID drivers

Compatibility: Can be used at the same time with all other hardware, or software.

2.0 Controls

Rear Panel

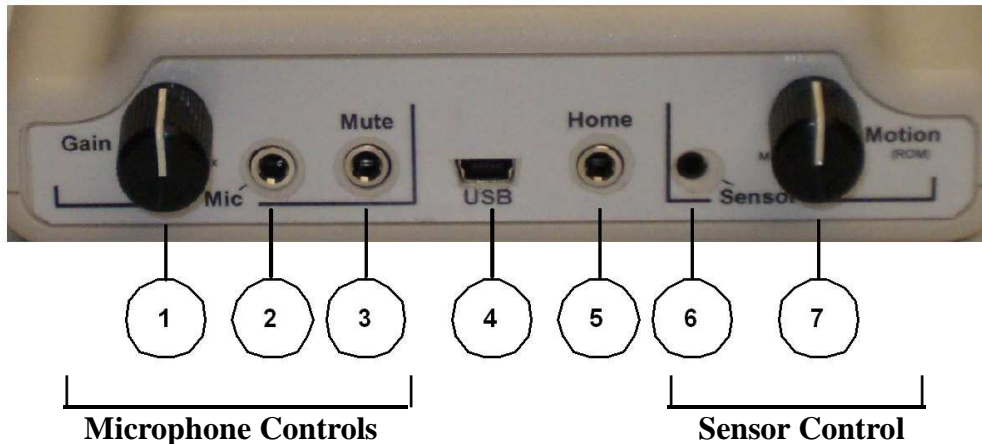

1. **Gain** – Controls amplification of the microphone. The higher the gain (CW), the more sensitive the microphone is.
2. **Mic** – Microphone input jack. Accepts microphones from most manufacturers using standard 3.5 mm plugs.
3. **Mute** – Microphone mute input jack. Mutes or disables the microphone input while switch is activated. This provides a way to prevent clicks during conversations. Accepts switch from most manufacturers using standard 3.5 mm plugs. Switch closure to ground activates mute function.
4. **USB** – USB input connector. Accepts standard USB mini-B cable from the host computer or AAC device.
5. **Home** – External Home input jack. Provides input for external switch to set the Home position instead of using button on top of unit. Accepts switch from most manufacturers using standard 3.5 mm plugs. Switch closure to ground activates Home command. Same functionality as Home button on top of unit.
6. **Sensor** – External sensor input jack. Accepts LaZee Tek’s external sensor modules. This proprietary interface is not compatible with other equipment.
7. **Motion** – Range of Motion (ROM) adjustment. Controls how far the sensor needs to tilt to reach full speed. The higher the motion setting (CW), the more tilt is required of the sensor.

2.0 Controls - continued

Front

- 8. **Home** – Home button sets a new home position for the sensor when activated.
- 9. **Left Click** – User feedback LED illuminates when left click occurs.
- 10. **Right Click** – User feedback LED illuminates when right click occurs



As a left or right click is detected, the appropriate LED will blink, indicating that click has been recognized and sent to the host computer. The **LED Intensity** can be adjusted if necessary.

Bottom

- 11. **LED Intensity** – Controls intensity of the feedback LEDs. Maximum (CW) position is brightest.
- 12. **Click / Drag Option** – DIP switch selects between two clicking options, allowing the user to select the best clicking function for their use.
 - a. **Option 0:**
 - i. One quick sound = left click
 - ii. Two quick sounds = double left click
 - iii. Single long sound = right click
 - iv. Extended long sound = right drag
 - b. **Option 1: (recommended for new users)**
 - v. Single quick sound = left click
 - vi. Two quick sounds = double left click
 - vii. Extended long sound = left drag
 - viii. Right button functions not available



3.0 Basic Functionality

Body Sensor

The body sensor is used to control the computer cursor. The Body sensor utilizes tilt sensor technology, and provides highly precise signals to control the cursor. It is operated by tilting slightly: forward/backward to control the up/down cursor movements and right/left respectively. A virtual joystick in space. . Because of its tiny size and extremely low weight, it can literally be worn anywhere the user needs it! Any part of the user's body can become a joystick.

Most importantly is to attach the sensor firmly to the activating surface and to support the cable so that it doesn't interfere with sensor travel during operation.

As a starting point, the user selects the "HOME" position. Cursor movement will not occur when the sensor is in this position. The HOME command performs electronic leveling, calibrating the sensor to its present position. This eliminates the need to level the sensor before use. The HOME position is updated each time the "HOME" button or external home switch is activated.

As the sensor is tilted, it sends signals to move the cursor. Tilting the front of the sensor up moves the cursor up, while tilting the front downward moves the cursor down. Returning it to the home position stops the cursor. Tilting the left side of the sensor downward moves cursor left. Tilting two directions at same time move the cursor diagonally. This provides smooth accurate cursor movements in any direction

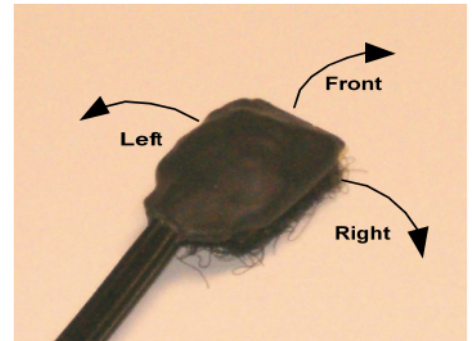

Cursor speed is proportional to the degree of sensor tilt. Tilt the sensor very slightly to move the cursor very slowly. Tilting the sensor farther increases the cursor speed until the maximum Motion setting is reached. Moving beyond this will not increase cursor speed any faster.

The "Motion" adjustment sets the Range of Motion (ROM) required for full cursor speed. The ROM is how far the sensor needs to be tilted to move the cursor at full speed. A minimum Motion setting will require the user to move very little in order to achieve full speed. While the "Motion" control selects how far a user must tilt the sensor to reach full speed, the maximum speed setting is set in the mouse properties menu. (4.0 Setup – Step 1)

The tilt sensor is reported to be the most reliable and accurate positioning system ever used in assistive technology computer control. One of its characteristics is that the sensor detects all movements, intentional and not so. When this is understood, the sensor can be installed and operated properly, thus providing the user the best computer control system available.

Refer to our Operational Notes section on the website for detailed explanations of various topics.

3.0 Basic Functionality - continued

Button Functions

The eeZee Mouse Pro detects sound via microphone, and uses it to perform click and drag functions. Spoken words, whistling, blowing, or puffing into the microphone can all be utilized to generate button functions. The most efficient and quietest method is to blow a puff of air, as you would if you were attempting to blow out a candle.

The length of sounds is used to determine between left & right button functions. A short sound is defined as less than 1/2 second while a long sound is greater than 3/4 of a second. A user selectable DIP switch selects from two modes of button operation:

- Option 0 provides for both left and right button functions
- Option 1 provides easier to use left button only functions

The microphone gain control is used to adjust the sensitivity of the microphone to match the user's operating conditions. LEDs are provided for visual feedback of when a Right or Left button action is generated. This can be a great tool when setting up a system for operation. Factors that affect button function performance include:

- Distance from mic to sound source
- Characteristics of microphone (noise canceling type is recommended)
- Mounting and positioning
- Background and intermittent noises
- User talking

The higher the gain setting, the more sensitive the microphone. In a quiet environment, the gain may be set to maximum. This will allow the least amount of sound to achieve the desired clicking activity. As the gain is reduced, the more sound is needed to for the LaZee Mouse Pro to recognize the click commands. With the gain set to minimum, no amount of sounds will trigger click commands. A higher gain setting, while able to detect soft puffs or air, can be more susceptible to unwanted background noises than a lower gain setting

An input for a microphone mute switch provides the user a way to disable button functions if desired. This could prevent undesired button activity, should the user need to carry on a conversation, etc..

Using an external Latch/Timer device between the mute switch and mute input jack provides for enhanced functionality and more flexible control options. This can provide a way to disable the mic for long periods of time without the user having to "hold" a switch active.

4.0 Setup

1. On host computer **reduce mouse speed settings to slightly above minimum**. Adjust as needed to match user's proficiency. Menu is located (in XP): *Start Menu / Settings / Control Panel / Mouse / Mouse Properties / Pointer Options* . Similar menus are available in other operating systems.

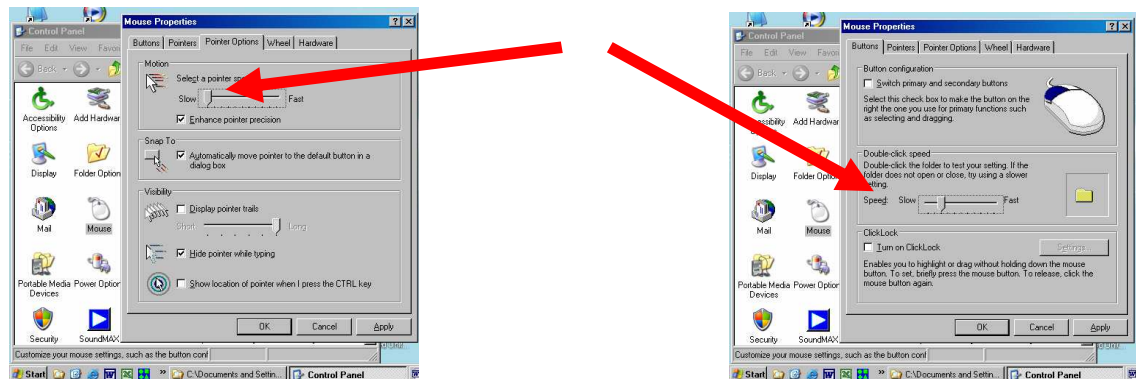

2. **Reduce double-click speed to a slower** setting if necessary. Menu is located (in XP): *Start Menu / Settings / Control Panel / Mouse / Mouse Properties / Pointer Options* .
3. **Enable “Click Lock”** function. Same menu as double-click speed. This is very useful when dragging often or for long moves. There are also other options in these menus that can be of great help when using alternative mouse devices. Please take a moment to look them over.
4. Set **LED Intensity** if desired to match environment. (on bottom of unit)
5. Set the **Click / Drag Option** DIP switch to desired position. (on bottom of unit)
6. Determine appropriate placement of eeZee Mouse. (New users may prefer to have it in front of them so as to be able to see the feedback LEDs)
7. Set microphone **GAIN** and sensor **Motion** controls to midpoint.
8. Connect microphone to the **Mic** input jack at rear of unit. Position microphone where user can use it without having to lean or change position to access it. (this could cause undesired cursor movements)
9. Connect external sensor to the **Sensor** input jack. Position sensor in desired operating position on user's head, foot, or **anywhere in between!**
 - a. Sensor must be oriented so as the cable exits toward the rear.
 - b. Sensor must be attached firmly to activating surface so as to not rock when activated.
 - c. Attach sensor cable clip to keep weight of cable from moving the sensor.

4.0 Setup - continued

10. If used, connect switch to the Microphone **MUTE** input jack. Position switch so it can be activated with as little change of position as practical. (aids in unwanted cursor movements while switch is activated.) Use of a Latch/Timer device can greatly enhance this feature.
11. If used, connect switch to external **HOME** input jack.
12. Connect small end of **USB** cable to eeZee Mouse.
13. Using standard ESD precautions connect large end of USB to host computer.
 - a. First time eeZee Mouse is connected to computer, it may be recognized as New Hardware. If so, wait several seconds for the “New Device Ready for Use” message.
 - b. Ignore any cursor movements until Step 2 below.

5.0 Operation

1. With user in normal computer operating position:
 - a. Look at the center of the computer screen and keep sensor motionless.
 - b. Set the HOME position by activating the HOME function either via external switch or pressing the button on top of eeZee Mouse. The HOME position is where the sensor is returned to when no cursor movement is desired.
 - c. Tilting the sensor in any direction will begin cursor movement.
2. Locate cursor and begin operation!
 - a. If cursor is off screen, moving in a circular pattern can aid in finding it.
 - b. Activate CTRL key if option is enabled in mouse properties menu.
3. Practice clicking to set the microphone GAIN control. Adjust Gain control toward maximum for the most sensitive settings. Spend time with your new system practicing clicking and dragging while monitoring the LEDs. Option 0 provides more capability with both L & R functionality, while Option 1 is much easier to operate, and is recommended for new users.
4. Speed settings **Rule of Thumb:** (Crawl before walking!)
 - a. Reduce Speed Frustrated or having difficulty
 - b. Increase Speed – Bored
 - c. Increase speeds if desired as skill develops.
5. For technical support see our Operational Notes Section or contact us:
 - a. Web: www.lazeetek.com
 - b. Email: support@lazeetek.com
 - c. Phone: 260 351-3274